

Manual Anchor Windlass

General Description:

Manual Anchor Windlass, also called hand windlass, is an equipment used for lowering and hoisting anchors and chains by man force.

Suitable for chain diameter: 12.5mm to 22mm

Driven Mode: Manual force

Application: for ship anchor handling

Certificate: Manufacturer's or CCS Cert.

Delivery Time: 30 ~ 45 days

Packing Method: Export Wooden Box

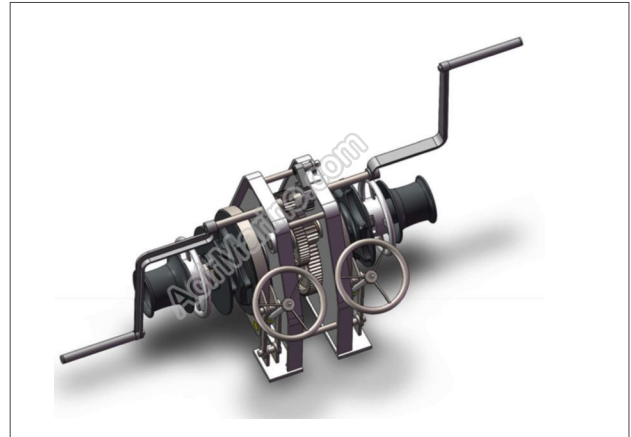

Drawing & components for manual anchor windlass

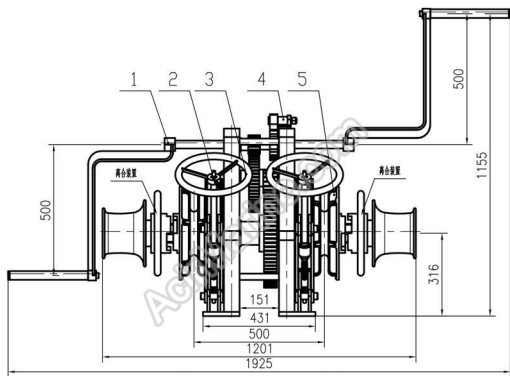

Consists of:

Two chain wheels, two warping heads

Main shaft, ratchet pawl device

Manual clutches and brakes

Stainless steel hand wheels

Side plates, gaskets and bolts, etc.

Painting Specification:

Abrasive blast with non-metallic abrasive grade SA2.5 according to ISO8501-1:2007.

First Layer: inorganic zinc epoxy primer -- 75um

Second and third layer: inorganic zinc epoxy primer --- 100 + 100um

Top coat: finished polyurethane coat -- 50um

Country of Origin:

Manual anchor windlass is designed by Acir Marine, and all components manufactured, assembled, and testing in Acir Marine workshop in China under strict quality control system.

CCS Certificate for Manual Windlass

Certificate No.: LY18P00134_01

Product: Manual Anchor Windlass

Chain Diameter: 19mm, AM2

Working Load: 11.7kN

Overload Pull: 17.6kN

Brake Holding Load: 37.4kN

